

INDUSTRIAL ROLLER DOORS

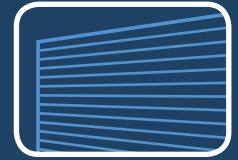

The most prominent visual feature of your building, factory or shed is often the garage door. So it makes sense to choose a Mirage Series B or C door because it's the ideal combination of strength, security and aesthetic appeal.

Series B

Series B industrial roller doors are designed to give you maximum value with all the advantages of the latest in door manufacturing technology. Each door is made to the highest industry standards and is available in a wide range of Colorbond® colours.

Series C

If protecting and enhancing your stock, equipment and business premises are important to you, then the series C roller door is the perfect choice.

It is without a doubt the strongest roller door manufactured for industrial and commercial applications.

Extremely robust, the series C roller door is available with a planetary gear chain drive - ideal for factories, warehouses and other industrial installations for openings up to 5100mm in height and 5400mm wide.

Thanks to its durable streamline design, the series C roller door has fewer working parts ensuring optimal performance and operation. No other continuous roller door has the same strength and durability as this market leading door.

Call 1800 465 599 or visit www.miragedoors.com.au



Quality Construction

Roll Formed Profile

The Mirage series B and C door curtains have unique roll formed profiles that are engineered and designed for superior strength whilst maintaining a unique appearance sure to enhance your building. Roll formed from genuine BlueScope Colorbond® or Zinalume® steel.

Nylon Felt Webbing

Mirage doors incorporate nylon felt webbing, fixed to both sides of the door curtain. This eliminates any metal on metal contact giving an extremely quiet and smooth operation for years to come.

Aluminium Bottom Rail

This heavy duty extruded aluminium bottom rail is designed to strengthen the bottom panel of the door. It incorporates a specially designed weather seal made from tough durable PVC.

Nylon Drum Wheels

All Mirage doors revolve on precision made nylon drum wheels, the latest in door technology. The doors are counter balanced using helical springs to ensure perfect balance and operation.

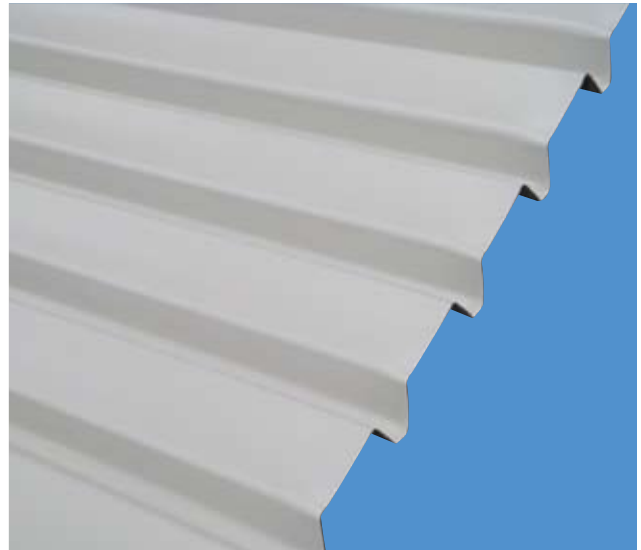

SERIES C PROFILE

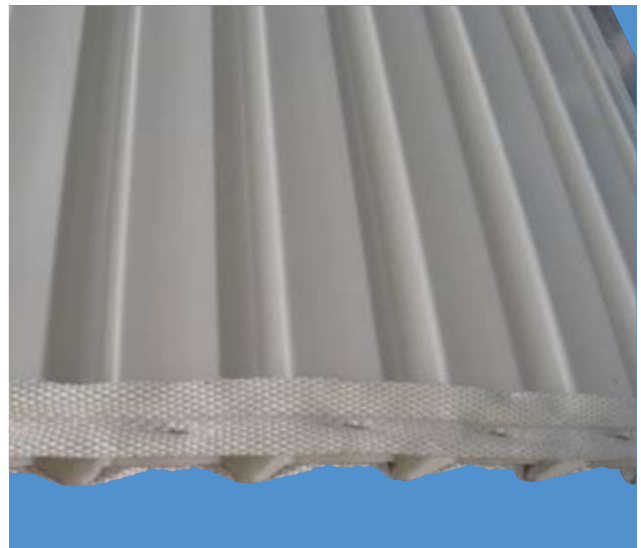

SERIES C WEBBING

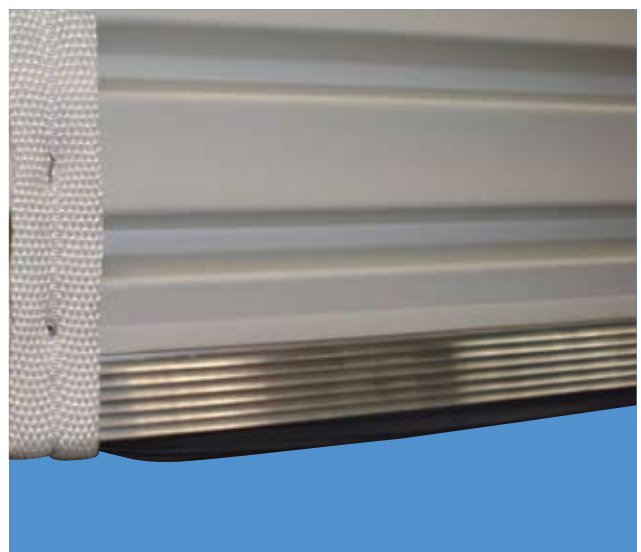

SERIES C BOTTOM RAIL

Applications

- Warehouses
- Factories
- Loading docks
- Industrial and rural sheds

Technical detail

- Direct or planetary gear chain drive with wall mounted locking cleat
- Optional bottom shute bolts
- Door curtain
- Nylon drum wheel
- Nylon felt webbing
- Heavy duty aluminium bottom rail with weather seal

Options

- Centre mullions
- Tapered bottom panel
- Centre lift lock
- Shute bolt locking
- Ventilation slots

Finishes

- Available in a wide range of Colorbond® colours

Operation

- Manual or automated





Technical Details

Use the following measurements and tables to ascertain clearances required and which type of drive chain is applicable.

Planetary gearing drive chain

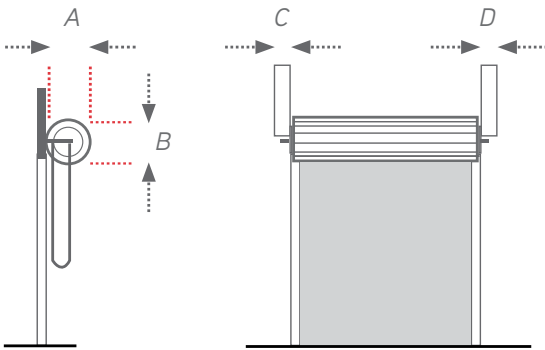

Direct drive chain

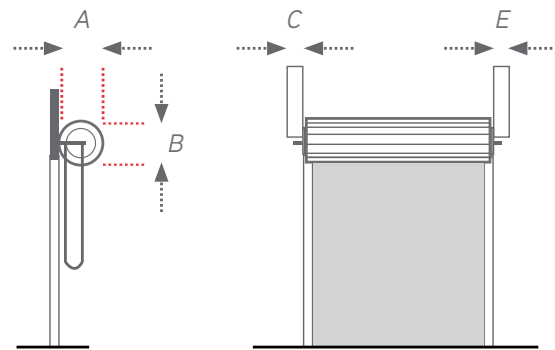

Table 1: Using this table we can ascertain the minimum clearance requirements for each roller door.

A - The required clear space from the header, back into the garage space

B - From the ceiling to the top of the door opening

C - The side room clearance for the non-drive side of the door

D - The side room clearance for fitting a planetary gear drive

E - The side room clearance for fitting a direct drive chain

Table 2: After sizing the door to the opening, this scale should be used as follows:

The height and width measurements are up to and including the height and width numbers on the scale. Therefore a door 3600mm high and 3600mm wide would be row 3600mm high and column 3760mm wide.

Then check the colour of the box with the scale directly below Table 2. In this example a direct drive is the standard.

Table 1

Opening Height mm	A	B	C	D	E
2400	470	590	115	-	-
2700	470	590	115	-	150
3000	510	630	115	-	150
3300	510	630	115	-	150
3600	510	630	125	200	-
4200	550	620	125	200	-
4800	590	710	125	200	-
5100	590	710	125	200	-

Table 2

Opening height mm \ Width mm	2800	3110	3430	3760	4370	5100	5400
2400	Grey	Grey	Grey	Grey	Grey	Grey	Grey
2700	Yellow	Yellow	Yellow	Yellow	Yellow	Yellow	Yellow
3000	Yellow	Yellow	Yellow	Yellow	Yellow	Yellow	Yellow
3300	Yellow	Yellow	Yellow	Yellow	Yellow	Yellow	Yellow
3600	Yellow	Yellow	Yellow	Yellow	Yellow	Yellow	Yellow
4200	Yellow	Yellow	Yellow	Dark Blue	Dark Blue	Dark Blue	Dark Blue
4800	Yellow	Yellow	Dark Blue	Dark Blue	Dark Blue	Dark Blue	Dark Blue
5100	Yellow	Yellow	Dark Blue	Dark Blue	Dark Blue	Dark Blue	Dark Blue

No chain
 Direct drive chain
 Planetary gearing drive chain

Mirage has a continuous program of product development and reserves the right to change specifications at any time without notice.

Call 1800 465 599 or visit www.miragedoors.com.au

