

Homeowner's

Wind Brace Door Manual

IMPORTANT

- Read this manual carefully and observe all warnings before operating or maintaining your garage door.
- The manufacturer recommends that the garage door be inspected and lubricated regularly as described in this manual. All other maintenance or repair of garage doors, especially any adjustment or replacement of the cables or components of the spring counterbalance assembly, is extremely dangerous and could cause serious personal injury if performed improperly. All maintenance or repair of garage doors, except inspection and lubrication, must be performed only by qualified door service personnel.
- Removal of a garage door is not a safe "Do-It-Yourself" project. Call a professional garage door repair person to remove the door if you plan to convert your garage into living space.
- Service calls as a result of lack of maintenance and/or lubrication will be charged for.

PURPOSE

Your Steel-Line Wind Brace sectional garage door is usually the largest moving piece of equipment installed and attached to the home or building.

As such, its weight can approach or exceed 200kg.

The manufacturer has designed and sized the components specifically for each door type, and you can expect to have efficient and safe operation of the door over an extended period of time, provided it is properly **installed, operated** and **maintained**.

IMPORTANT SAFETY NOTICE

1. Operate the door only when properly adjusted and free of obstruction.
2. The door is constantly under extreme spring tension. Repairs and adjustments, especially to cables and spring assembly, can be hazardous and should be performed only by a trained door technician.
3. Do not permit children to play with garage door, push buttons or electric controls.
4. If door is now, or later becomes electrically operated, pull-down rope/s, **MUST** be removed. Also make lock inoperative or remove.
5. Avoid standing in open doorway at any time or walking through doorway while door is moving.
6. Should door become hard to operate or completely inoperative, call your Steel-Line representative for repair.
7. Do not paint track, rollers, hinges, lift cables, springs or locks.

MAINTENANCE

All mechanical devices require periodic service and/or maintenance, and garage doors are no exception.

The amount and frequency of preventive maintenance required depends on the frequency of operation, geographical location and the environmental conditions. Preventive maintenance should be performed at least every six months, and more frequently if conditions warrant.

Unless the user is experienced in the maintenance and repair of garage doors maintenance should be limited to the lubrication of moving parts, and inspection of certain components or tightness.

REPAIRING SPRINGS AND CABLES is a DANGEROUS PROCEDURE and may cause physical injury if improperly performed, and should be performed ONLY by qualified door service personnel.

"Remember your Steel-Line Garage Door is a moving mechanical product and just like a car it needs to be serviced regularly."

IMPORTANT

It is important that the tracks and hinges on your new garage door be kept free from dust and dirt. In particular brick dust from brick work and brick paving can be a problem in new dwellings as well as dust and dirt in newly developed areas.

Ensure that the tracks and hinges are clean.

Note: Signs of the tracks and hinges needing attention can be as follows:

1. The door is excessively noisy.
2. The door reverses direction during the closing action and returns to the open position.

Service calls as a result of lack of maintenance are not covered by your warranty and will be accompanied by a service charge.

DOOR TRACKS

Maintain tracks free of oil or grease to enhance operation of track rollers. Grease in tracks attracts dirt and dust which builds up and impedes smooth operation of door.

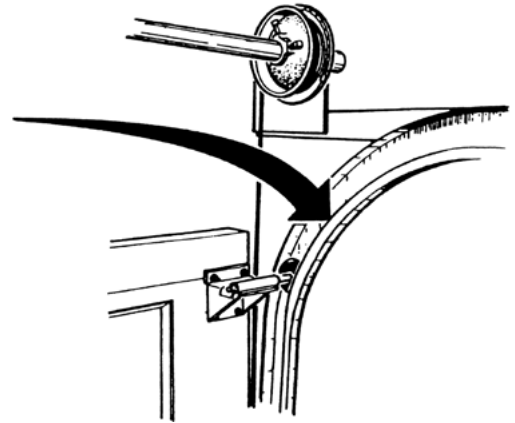

LUBRICATION

LIGHTLY OIL:

- Hinge Points
- Steel Rollers: roller stems and inner race of assembly
- Non-metal Rollers: plastic rollers are self lubricating and require no lubrication at the race of the bearing - only the roller stems.
- Locking Device: moving parts
- Torsion Spring Assembly: Spring coil surfaces (grease is preferred)

Lubrication in general, reduces wear and friction, and a 30 W or other medium weight oil is satisfactory.

If desired, an aerosol similar to Inox may be used. Wipe off excess oil from door and track surfaces. To lubricate spring grease should be used.

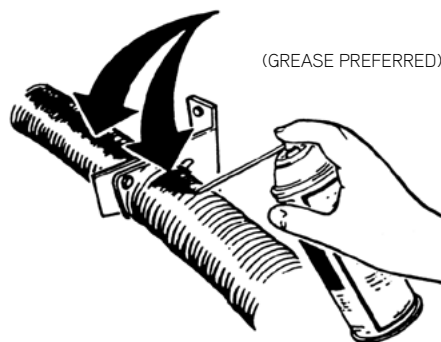
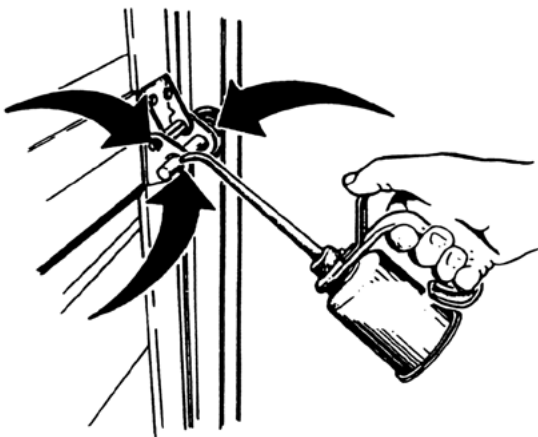

DOOR PANELS

The door panels are manufactured from genuine BlueScope Colorbond® or powdercoat finish and should be washed regularly to remove corrosive salt and dirt.

"when you wash your car remember your Steel-line door."

HARDWARE INSPECTION

With the door in the down, closed and locked position, inspect hinges, top fixtures, bottom fixtures, locking devices, and track brackets to make sure that they are securely affixed with fasteners. Re-tighten as necessary, but **DO NOT** over tighten. Excess torque may strip the threads and render the fastener useless.

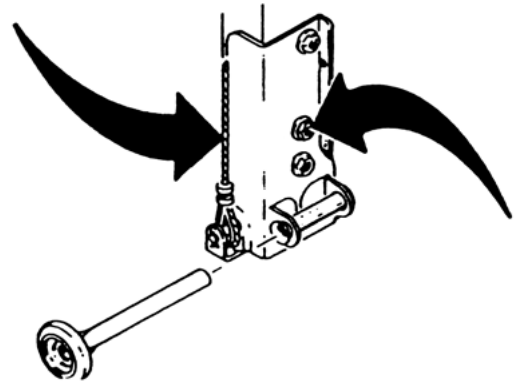
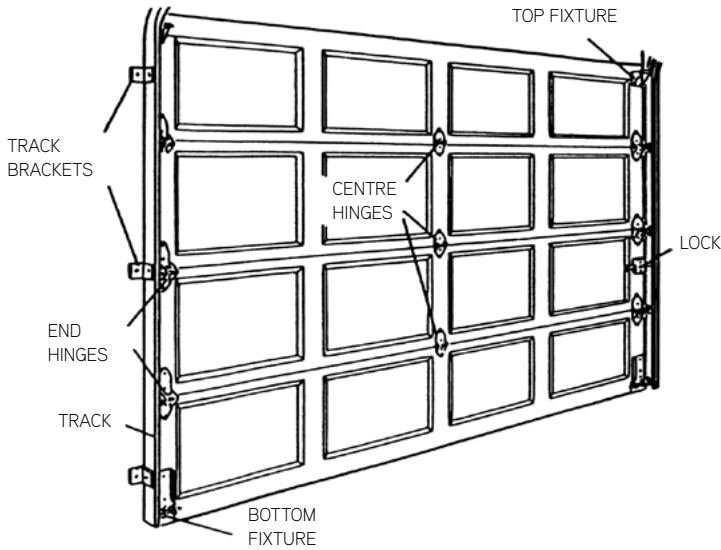

CABLE INSPECTION

With the door in the down, closed and locked position, inspect to insure cables are taut and secured to bottom fixture. Cables must be unobstructed from bottom fixture to cable pulleys or cable drum. Inspect for frayed or broken strands.

WARNING

The cables transport the full weight of the door and must be free of frayed or broken strands.

Replacement of cables is a dangerous procedure and should be performed only by experienced door personnel.

Cables are attached to the bottom fixture and extreme caution should be used in tightening fasteners. **NEVER LOOSEN** fasteners on the bottom fixtures.

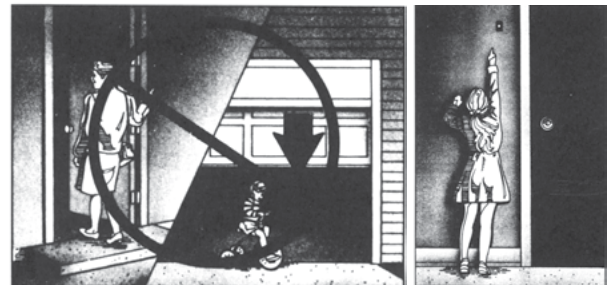

SPRINGS

WARNING

NEVER LOOSEN any fasteners on the torsion spring counterbalance assembly.

Replacement or adjustment of any components of the Spring Assemblies is a **DANGEROUS PROCEDURE** and may cause physical injury if improperly performed.

Forces generated in springs are generally equal to the door weight, and those forces are violently released if a spring breaks while wound or stretched.

If a spring breaks, **DO NOT ATTEMPT REPAIR**; call your nearest Steel-Line representative.

DO NOT attempt to **LOOSEN** any fasteners associated with the Spring assemblies or Cable assemblies, as it could cause the spring to unwind or release or the door to fall if it is in the open position.

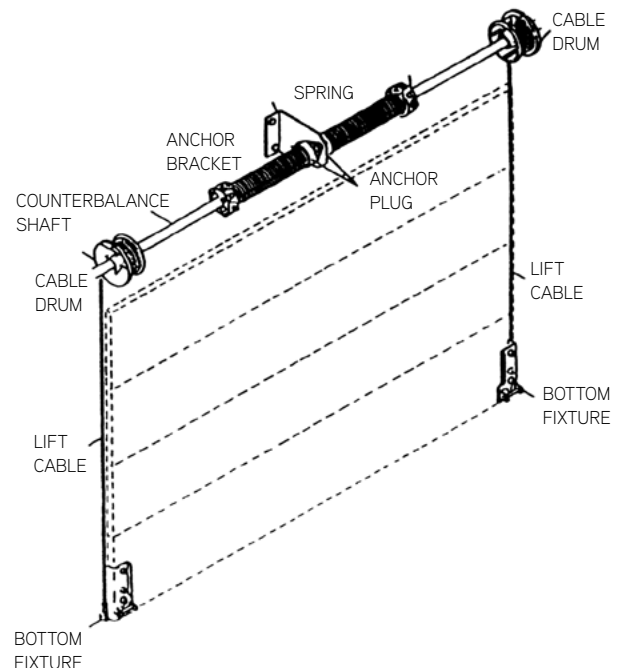

INSTALL & REMOVE WIND BRACE POST

TO INSTALL

STEP 1: Insert post base “key” into base plate on floor, taking note to orient post “key” to match shape in base plate.



STEP 2: Rotate post in base plate ¼ turn so that top arm faces wall bracket. Secure post temporarily to a stile using the chain from one of chain brackets (this prevents post falling over while doing Step3).



STEP 3: Lift top inner post and fix to wall bracket, by removing the pin, inserting top arm into bracket clevis and re-installing the pin.



STEP 4: Feed chain under & over strut & hook back onto chain bracket. Repeat for all post to strut connections.



TO REMOVE

Reverse the steps noted above.

GARAGE DOOR OPENERS

Garage Doors Openers are not toys!

Do not stand, walk or drive vehicles under a moving door! Do not let children play "beat the door." It is very dangerous and can result in serious injury or death. Adults should set a good example.

Keep transmitters and remote controls out of reach of children. Do not let children play with or use the transmitters or remote controls.

The push button wall control should be out of reach of children (at least 1.6 metres from the floor) and away from all moving parts. Mount and use the button where you can clearly see the closing garage door.

The use of the optional Photo Eye Protection is strongly recommended.

TESTING THE OPENER

Your opener has a reversing feature and should be tested every month.

With the door open, place a 70-100mm thick piece of wood, laid flat, on the floor in the door's path at approximately the centre of the door. Push the control button to close the door. The opener must reverse and open the door when it strikes the wood. If the opener does not reverse, have it repaired. Have a qualified individual adjust your opener. Test the force setting of your garage door opener by holding up the bottom of the door as it closes. If the door does not reverse readily, the force is excessive and needs adjusting. Your garage door opener should be adjusted by a trained door technician (this is not covered under warranty).

The reversing feature on this operator is only a precautionary system. The Manufacturer strongly recommends the fitting of optional Photo Eye for protection.

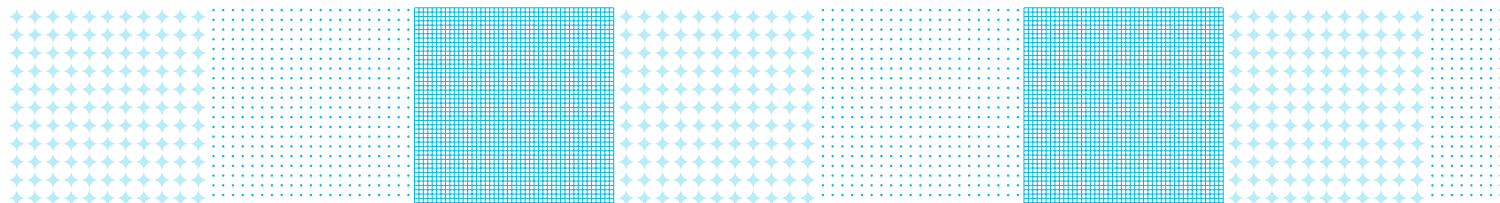
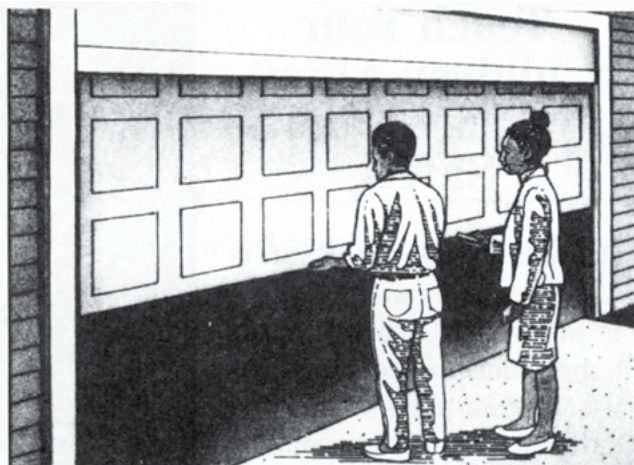
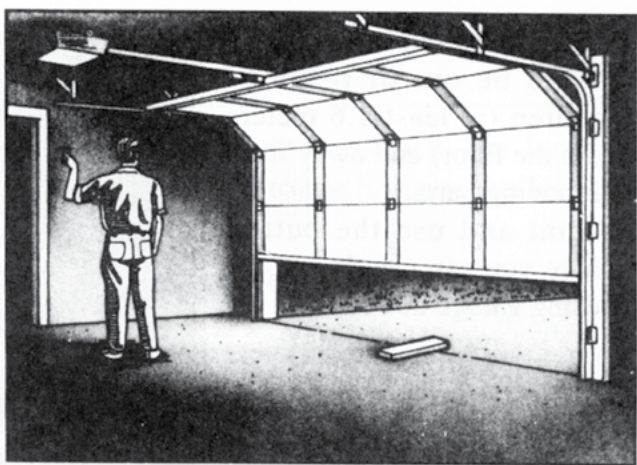

Call 1300 427 243 | steel-line.com.au

**makers
for life**