



SC12 Aluminium Roller Grille

FEATURES

- VISION
- VENTILATION
- SECURE
- ROBUST
- EASILY INSTALLED

The SC12 Aluminium Roller Grille offers an attractive solution for many applications that require a secure barrier against theft and debris and where visual access, airflow and light infiltration are a key design consideration.

The SC12 Aluminium Roller Grille features a brick like pattern.

The SC12 Aluminium Roller Grille is constructed from aluminium tubing for full width opening connected with moulded nylon links providing a secure operable curtain.

Extruded bottom rail is also available and can be fitted with a concealed two way lock or lockable shoot bolts. Waist high locking is also available. Side guides are extruded aluminium with an optional Nylon Felt Buffer is available.

Application

From Shopfronts, Pedestrian Openings, Arcades, Bar Tops and Counter Tops with an opening size up to 3.6 metres high and 3.6metres wide for hand operation.

Curtain

Constructed of 12.7mm aluminium tubes at 50mm centres connected with 110mm x 20mm x 10mm nylon links spaced at 270mm centres (standard) and 220mm centres (security) to form each grilles specific pattern.

Side Guide

50mm x 33mm extruded aluminium with false back for concealing fixings. An optional Nylofelt Buffer is also available.

Locking

Locking shall be centrally mounted, Two Way Mortice Key Lock or Sliding Shoot Bolt Locking mounted within the bottom rail (it can be inside or outside locking).

Optional waist high locking is also available.

Bottom Rail

90mm x 48mm extruded aluminium section incorporating locking device and concealed locking rods and an optional PVC Buffer is also available. The brackets are manufactured from 90mm x 40mm mild steel.

Roller Drum

Manufactured from 150mm or 229mm spiral ducted tube attached to self-lubrication drum wheels and bearings rotating on a 34mm diameter steel shaft (for manual operation).

The shaft shall be fitted with helical sprints designed to counterbalance the curtain weight throughout its operation. The drum shall be designed to give minimum deflection over the span.

Mullions

Mullions shall be two piece extruded aluminium section that can be set to any angle and can be applied for wide openings and multiple door installations. Mullions shall be 'lift out type' with shoot bolts to base.

Special wide mullions fabricated from aluminium sheet shall and used when two grilles meet at an angle and no room exists for stacking (please refer mullion details).

Operation

The SC12 Aluminium Roller Grille is designed for manual hand operation as standard or motorisation or chain is optional as required.

Finish

The SC12 Aluminium Roller Grille is available in anodised finish and powder coated colours.

Bulkhead Details

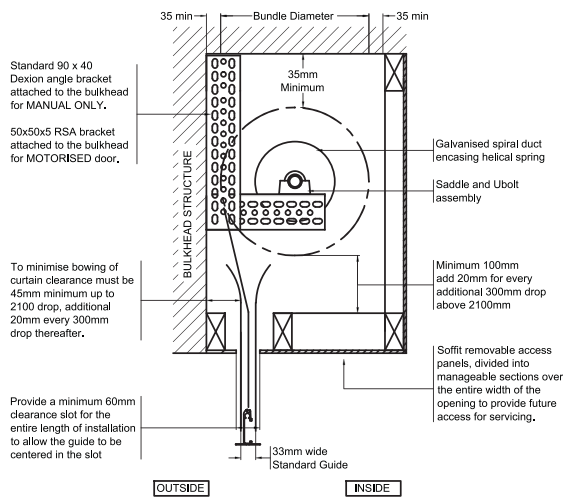

Curtain Details

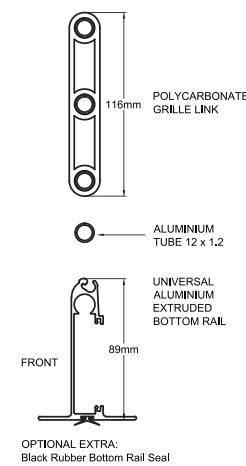

Guide Details

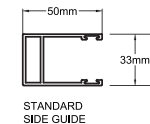

Mullion Details

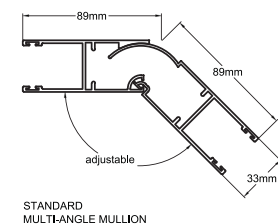
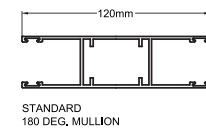

Bundle Diameter

Manual Door	Drop	1200	1500	1800	2100	2400	2700	3000	3300	3600
203mm Drum	Bundle	330	350	360	370	380	390	410	420	430
Motorised Door	Drop	1200	1500	1800	2100	2400	2700	3000	3300	3600
229mm Drum	Bundle	360	370	380	390	400	410	420	430	440

Steel-Line reserves the right to change specifications at any time without notice.

MD031-SC12-V1 (0715) Copyright © Steel-Line Garage Door Australia. All rights reserved.